

Topaz Ultra

PSA Oxygen Generator



Ordering Information

Product	Part Number
Topaz Ultra Oxygen Generator (120V/60 Hz).....	AS123-1
Topaz Ultra Oxygen Generator (220V/50 Hz).....	AS123-2

Pricing for above includes:

Compressor Assembly

Accessory Kit—includes the following:

- Instruction Manual
- One (1) Extra Gross Particle Filter
- Brass Barbed Hose Connector

Features

- Produces oxygen from compressed air
- Microprocessor controlled
- Low operating cost
- Automatic and unattended operation
- Easy to install and maintain

Typical Applications

- Ozone (Generator) Feed Gas
- Waste/Water Treatment
- Thermal/Chemical Oxidation
- Environmental Remediation
- Glass Work/Blowing
- Fish Farming
- Brazing/Soldering

The Pressure Swing Adsorption (PSA) Oxygen Generating Process

Air contains 21% oxygen, 78% nitrogen, 0.9% argon, and 0.1% other gases. AirSep Oxygen Generating Systems separate oxygen from compressed air through a unique Pressure Swing Adsorption (PSA) process. The PSA process uses molecular sieve (a synthetic zeolite), which attracts (adsorbs) nitrogen from air at high pressure and releases (desorbs) it at low pressure.

AirSep Oxygen Generators use two vessels filled with molecular sieve as adsorbers. As compressed feed air flows through one of the vessels, the molecular sieve adsorbs nitrogen. The remaining oxygen passes through the vessel and exits as the product gas. Before the adsorber

becomes saturated with nitrogen, the feed air is diverted to the second vessel. At that point, the sieve in the first vessel regenerates by desorbing the nitrogen through depressurization and purging it with oxygen from the second vessel. This process is then repeated in the second vessel to complete a cycle that allows the oxygen generator to deliver a constant flow of product oxygen at 90% minimum purity. Under normal operating conditions, the molecular sieve is completely regenerative and will last indefinitely.

AirSep offers a wide variety of standard PSA oxygen systems to supply virtually any oxygen application from 12–5,000 SCF/hr (0.32–131 Nm³/hr) of product oxygen output.

AirSep also designs and constructs larger engineered systems.

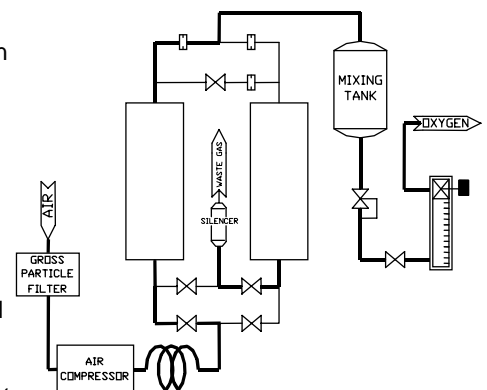

Topaz Ultra

PSA Oxygen Generator



For additional information,
call Toll-Free U.S./Canada:

1-800-320-0303

Specifications

Product Characteristics

Standard Product Flow: 21 SCF/hr¹ (0.55 Nm³/hr²)

Standard Product Pressure: 20 psig (137.9 kPa)

Minimum Product Purity: 90%

Product Dew Point: -100°F (-73°C)

Ambient Operating Conditions

Locate the oxygen generator in a well-ventilated area that is protected from weather elements and remains between 40°F (4°C) and 112°F (44°C)

Control Power Requirements

120 V ~ ±10%, 60 Hz, Single Phase, 6.0 A

220 V ~ ±10%, 50 Hz, Single Phase, 3.0 A

Typical Power Consumption (at 90% purity): 590 W

Physical Characteristics

Dimensions (W x D x H): 17.3 x 10 x 26.8 in.
(44 x 26 x 68 cm)

Weight: 58 lb. (27 kg) [Add 4 lb. (1.8 kg) for 220 V ~ unit]

Physical Connections

Product Gas Outlet: 1/4" NPT/B size oxygen adapter

Sound Level: 58 dba @ 1 meter, open field conditions

Warranty: 1 Year Parts and Factory Labor*

*An unprotected or inadequately ventilated environment or improper control power may cause damage to the oxygen generator not covered under warranty.

AirSep Corporation continually improves its products and reserves the right to change specifications or design without notice.

Oxygen Generators manufactured by the Commercial Products Division of AirSep Corporation are sold for use in industrial applications only. Contact AirSep Corporation or an authorized AirSep representative before purchasing a unit for any medical application.

Commercial Products Division
260 Creekside Drive
Buffalo, NY 14228-2075 U.S.A.
Tel: (716) 691-0202
Fax: (716) 691-1255
URL: <http://www.airsepcpd.com>
E-mail: cpd@airsep.com

¹ SCF (Standard cubic foot) gas measured at 1 atmosphere and 70°F

² Nm³ (Normal cubic meter) gas measured at 1 atmosphere and 0°C

AirSep Topaz Ultra Oxygen Generator
Performance Curve
20 psig Delivery Pressure

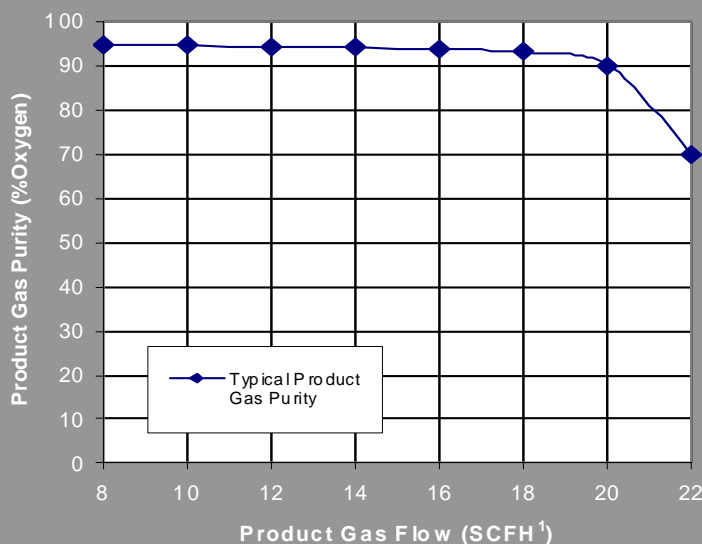

Note: A standard Onyx Ultra delivers 21 SCF/hr¹ (0.55 Nm³/hr²) of 90% minimum purity oxygen at a pressure of 20 psig (137.9 kPa). Generator performance will vary slightly in accordance with ambient air temperature and site conditions.

Shipping Information:

Ships as a Class 92 or 92.5

Class: Non Hazardous Goods

Commodity Classification Number: 8405.10

Dimensions (W x D x H): 21 x 12 x 29 in.
(53 x 31 x 74 cm)

Weight: 66 lb. (30 kg) [Add 4 lb. (1.8 kg) for 220 V ~ unit]