



Reclaim Filters and Systems, Inc.

Ozone Series Manual



model **K2**

ozone generator



©RECLAIM Filters and Systems, Inc.
1129 Hidden Hills Dr.
Wake Forest, NC 27587
(919) 528-1787 phone
(919) 528-7217 fax
www.waterreclaim.com website
info@waterreclaim.com email

Table of Contents

CHAPTER 1	
INTRODUCTION	1
SYSTEM DESCRIPTION	2
CHAPTER 2	
SPECIFICATIONS	3
CHAPTER 3	
INSTALLATION	4
CHAPTER 4	
OPERATION	7
Ozone manifold set-up	8
CHAPTER 5	
TEST DATA	9
CHAPTER 6	
WARRANTY INFORMATION	11
CHAPTER 7	
MSDS INFORMATION	16

Chapter

1

Introduction

General

This manual is intended to give you the information needed to use the RECLAIM K2 ozone generator. The sections detail: System Description, Installation, Operation and Maintenance.

Warnings, Cautions, and Notes

As you read the manual, these symbols will let you know to pay special attention to the CAUTION, WARNING, and NOTE messages. These help to identify important safety issues or other important items.



CAUTION Information that could prevent system damage or minor personal injury.



WARNING Information that can prevent injury or death.



NOTE Just an FYI. Useful or interesting information.

System Description

The K2 ozone generator utilizes the corona discharge method of producing ozone from oxygen. The corona discharge method utilizes a high voltage to energize oxygen atoms, enabling them to accept a third atom in the molecular structure. The high voltage plasma is the energizing force enabling the O₂ to cling to another oxygen atom creating O₃.

The K2 unit is a single power supply and corona cell unit. The ozone generator, depending upon gas flow oxygen concentration and temperature, can produce from 0 to 10 Gm/hr of ozone.

Features of the – K2- ozone generator

- Non corrosive stainless steel case
- Water trap air ventilation
 - Helps to prevent water damage
- Built in safety devices
 - Door interlink removes power when door is
 - Flow switch shuts off unit if gas flow is interrupted
 - Fused circuit boards
 - Integrated power filter, surge suppressor
 - U.L listed materials for non flammability
- Continuous duty rated
- Air cooled
- Integrated Flow Meter
- Brass oxygen/air inlet barb fitting
- Stainless Steel ozone outlet barb fittings
- Power on light integrated into splashproof switch
 - illuminates when gas flow is established.

Chapter

2

Specifications:

- Dimensions
 - (H 21" x W 14" x D 8")
 - Mounting holes 8" across x 191/8" top to bottom
 - Shipping weight 24 lbs

- Type: Corona Discharge Ozone Generation
- 21.2 gm/hr with oxygen (98% O₂ @ 6 Lpm)
- Ozone output purity 4.6% by weight (gas temperature 70°)
- Operating pressure from -2 to 15 psi
- 110-120 vac 60 Hz. U.S. or 220-230 vac 50 hz European
 - Current draw 3.2 amps RMS @ 115 VAC 60 Hz
 - Current draw 2.1 amps RMS @ 230 VAC 50 Hz
 - Power consumption 265 watts.
 - feed from 7.5 amp breaker
 - Incoming line filter, surge suppressor carries UL, CSE, ETL certifications
 - Peak surge suppression 600VAC (class 6 solid state relay)
- Operating temperature from 33° to 90° Fahrenheit
- Cord length 6'
- Case material 304 Stainless Steel
- Corona cell material borosilicate glass, ceramic, and 7075 aluminum

See K2 drawing on page 3 for exact mounting dimensions



NOTE: ozone output is temperature dependant and inversely proportional to cooling air and inlet gas temperature.

Chapter

3

Installation:

DUAL CELL OZONE GENERATOR FRONT VIEW

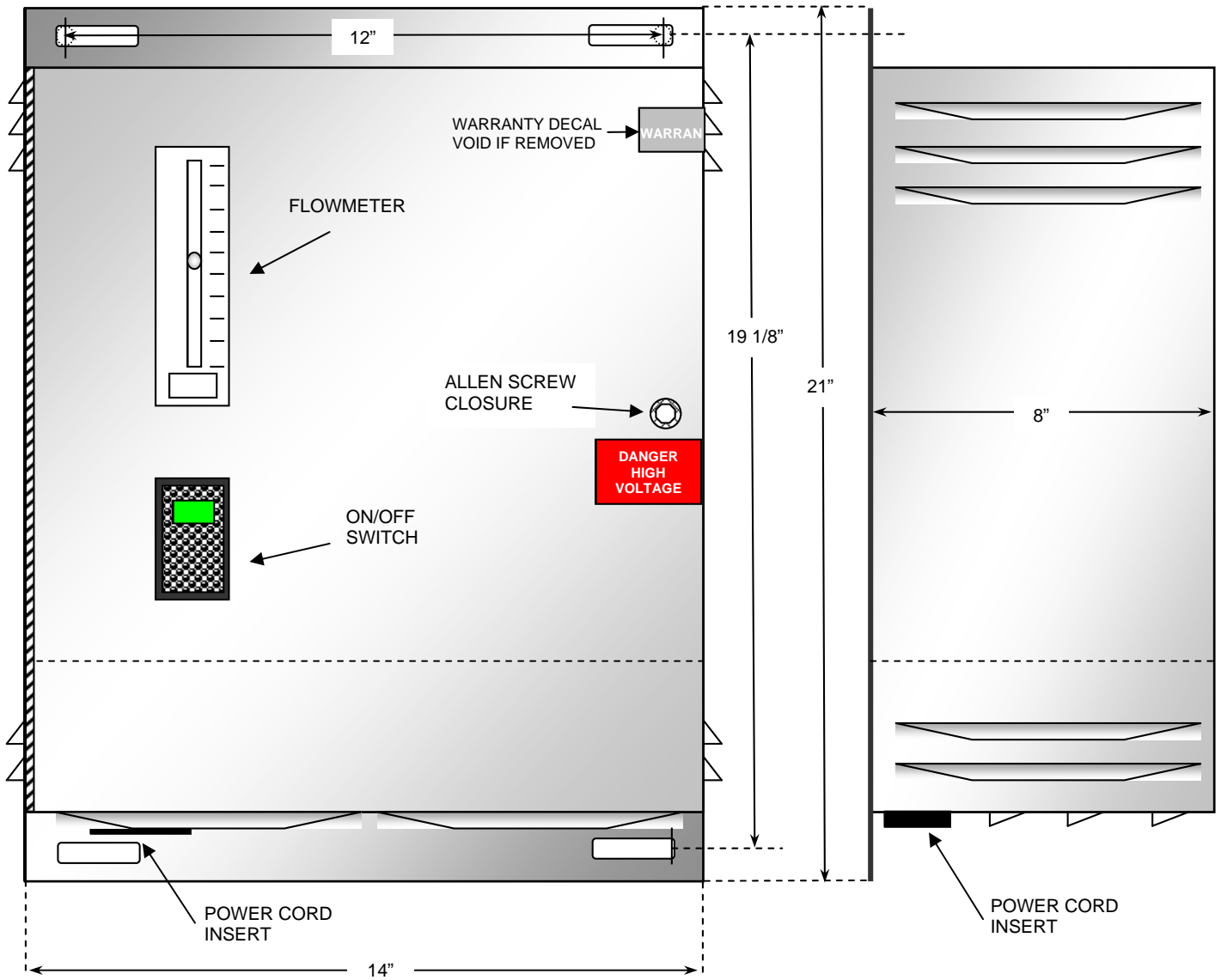

Installation Cont.

1. 304 S.S. ENCLOSURE

Mounted to wall or other secure structure

2. HINGED ON LEFT

Unit opens on right and door swings away to left. Allow space for service inspection.

3. AIR VENTS ON SIDES AND BOTTOM

Allow 6" around unit for air circulation. Prevent hot exhaust from other equipment to enter ozone generator. For example do not mount the ozone generator on the exhaust side of an oxygen concentrator

4. WARRANTY PLACARD ON FRONT AND SIDE

a. Void if removed, no user serviceable components. Do not open during warranty period.

5. WARNING HIGH VOLTAGE DECAL



a. High voltage exists in the cabinet. There are no user serviceable parts inside, if the cabinet is opened the warranty is voided.

6. MOUNTING HOLES 3/8"

a. Spacing

i. 12" x 19 1/8"

7. WEIGHT 20 LBS

8. UNIT MUST BE MOUNTED VERTICALLY

9. INSURE ADEQUATE AIRSPACE AROUND UNIT FOR VENTILLATION



a. The stainless steel enclosure acts as a heat sink and helps to keep the corona cell producing at the optimum level and insures longevity.



OPTIONAL AUX CONTACT INSTALLATION

- Aux contacts located on lower left underside
- Remove jumper for remote control
- Install (14 to 16 ga insulated) wires from remote relay contacts to the terminals
- Use proper terminals as bare wires tend to come loose
- Follow the instructions provided with your ORP controller

Chapter

4

Ozone generator operation:

POWER-UP

1. Please insure all installation steps have been performed and adequate ventilation is provided.
2. If air / oxygen flow is established and unit power switch is in the UP position, the green (110 vac) or red (230 vac) indicator light will illuminate.
3. Verify desired flow rate. Normally between 6 and 8 lpm (liters per minute)
4. The ozone generator is designed for continuous duty operation. If the green or red power light is illuminated you have power to the corona cells and are creating ozone.

SYSTEM OPERATION

1. In some applications the unit will not power up directly. Some high end water reclamation systems allow a warm up period for the oxygen concentrator. There may be a 60 second delay in ozone generator start-up after the oxygen concentrator has been switched on.
2. The flow meter indicates the amount of dry air or oxygen flowing to the corona cells that produce the ozone.
3. If the unit power light does not illuminate insure you have gas flow indicated on the flow meter. The safety flow switch will de-energize the unit if the flow drops below 4 lpm.
4. There is no user required maintenance on this unit. The ozone cells have a life expectancy of 16,000 hours. This is approximately two years of continuous duty operation. Cell life is dependant upon:
 - a. Temperature
 - b. Inlet oxygen or dry air quality
 - c. Humidity
5. The unit will require maintenance after that period and should be returned for cell replacement.
6. Contact your dealer or the mfg listed above for service information.

OPTIONAL AUX INPUT REMOTE CONTROL

If the aux input control is installed you may control the unit remotely via an ORP controller. This will allow the corona to be turned on and off while keeping the fans running to prevent thermal shock to the corona cells.

1. Attach the two wires (14 – 18 ga) to the terminals located at the bottom left of the unit. See page 5 for location and description
2. The aux contacts route a neutral AC line to an external relay like an ORP or ozone controller.
3. If no controller is used a jumper needs to be installed between the two contacts for normal operation.

Ozone Manifold Set-up

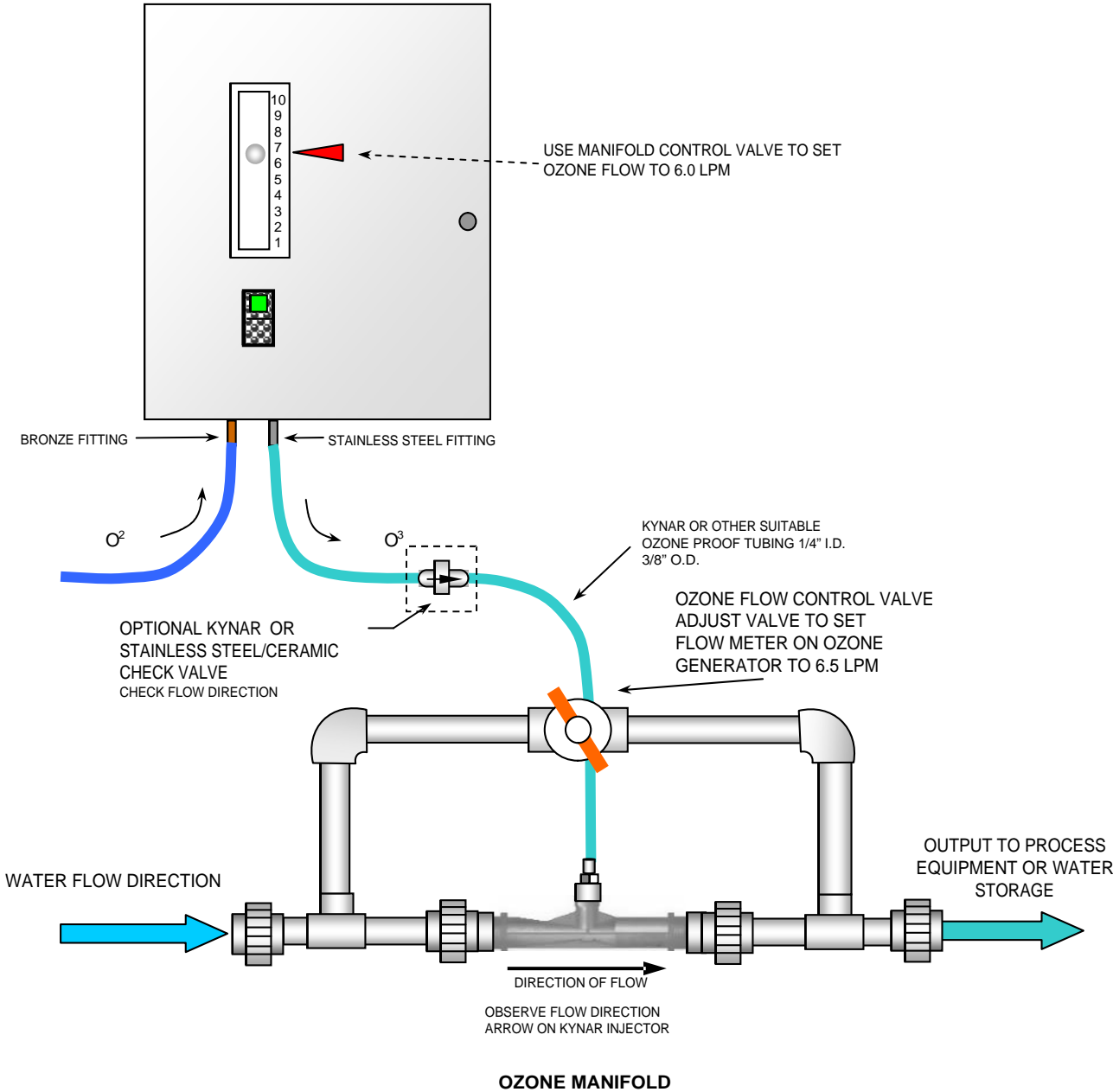

Ozone Manifold Set-up cont.

1. Use flexible Ozone resistant Flexible tubing like (PVDF) KYNAR or Teflon, from the Ozone Generator (stainless bottom fitting labeled OZONE OUT, to the point of use. 3/8" OD X 1/4" ID tubing.
2. Use flexible .oxygen proof tubing from the oxygen concentrator to the ozone generator's brass fitting on bottom labeled OXYGEN. 3/8" OD X 1/4" ID
3. Insure the Ozone Generator is **OFF** until proper flow is set (see following instructions)
4. Flow adjustment: With ozone output disconnected, set feed pressure on oxygen concentrator so the flow meter on the Ozone Generator reads the desired flow, from 3.8 to 10 LPM (liters per minute)



To protect your ozone generator a flow switch is installed that will shut the unit off if oxygen flow is interrupted.

FOR INJECTOR APPLICATIONS (begin with Ozone Generator OFF)

1. Disconnect the oxygen input from the Ozone Generator. With a stabilized water flow through the ozone injector manifold, set the ozone control valve to raise or lower the flow ball indicator to desired flow. See your injectors spec sheet for optimum flow. For example a Mazzei 1078 1" venturi produces the finest bubble size with a flow of 20 GPM (gallons per minute) with a suction inlet volume of between 5.5 and 6.5 LPM..
2. Disconnect the ozone output from the Ozone Generator and reconnect the oxygen to the brass oxygen input. Turn on the oxygen concentrator or start the flow of O2 gas. When the flow is stabilized set the flow as shown on the Ozone Generator to the same reading as step 1. For example if you set the PULL from the venturi at 6.5 LPM you will set the PUSH from the oxygen concentrator at 6.5 LPM. The goal of this step is to balance the two forces.
3. With the pressure and vacuum stabilized and equal reconnect the hoses. Turn ON the Ozone generator and place into operation.



NEVER RUN OZONE GENERATOR WITHOUT OXYGEN FLOW.

A Balance barometer may be used in place of optional ozone proof check valve.
See balance barometer set-up sheet (optional)

Chapter

5

K2 Test Data:

OZONE OUTPUT

Ozone output is dependant upon several variables which include:

- Temperature of feed gas
- Purity of feed gas
- Voltage of Corona Cell
- Resonant frequency of gas plasma chamber
- Temperature of Corona Cell
- Pressure
- Humidity

A cool clean dry oxygen feed will provide the best results. Temperature is inversely proportional to ozone production, therefore as temperature increases ozone production decreases. Keeping the unit in a cool dry location is important.

The test data provided to Edison Testing Labs for certification is attached.

See Page 10 Ozone Test Data.

If for some reason you feel the ozone output is insufficient first check the oxygen feed gas for purity and flow. The corona discharge cell in the K2 does not diminish in output over time like U.V. and other methods of ozone production. If the corona cell is powered it will produce ozone.

Unit under test RECLAIM Filters & Systems, inc. K 2
 Test date 4/17/2006

measured 63.3 in g/m3 as read on test equipment
 % weight 1 2 3 4 5
 g/m3 14.1 28.4 42.7 57.2 71.7

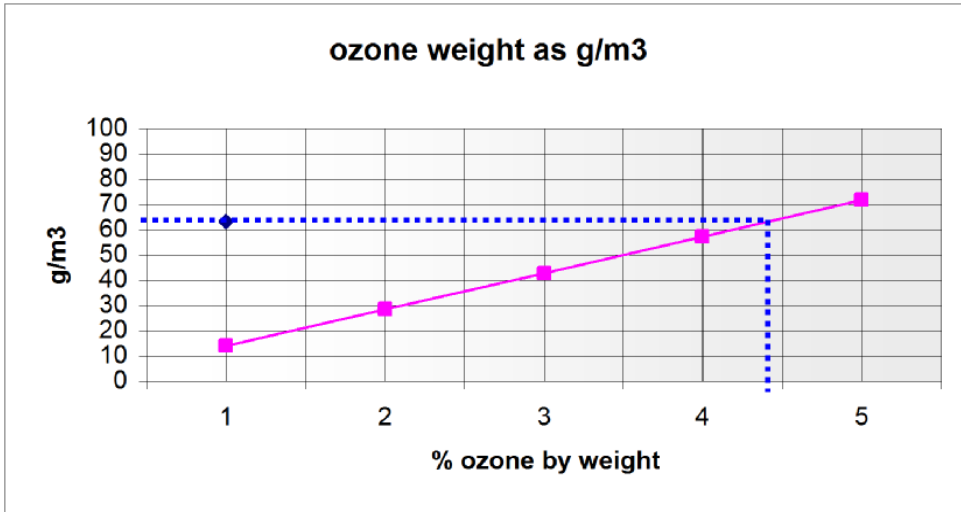

Ozone output 4.4% by weight.

Grams per hour calculation

concentration (g/m3) x flowrate (lpm) x 0.001 = O3 output (g/min) x 60 = g/hr

Enter readings:

g/m3 63.3 as shown on test equipment
 lpm 5.6 as shown on ozone flow meter or output of O2 unit
 O2 input 5 PSI to corona cell (41 kPa)

Output:

g/min 0.35448
 g/hr 21.2688
 lb/hr 0.046791
 lb/day 1.122993



Notes:

Unit tested with AS 12
 Tested with corona cell mounted vertically
 105 CFM Tubeaxial fan mounted on side blowing across cell and PS.
 oxygen concentrator at 5.6 lpm 98.9% o2.
 Ambient air temp 71 f
 Ozone Tester Calibration date 1/24/06 Applied Ozone Technology.
 AS12 or AS12A pressures above 9 psi cause 15% fluctuation in pressure and O3 reading.
 Do not exceed 7 psi during tests for steady and accurate readings.
 Allow units to temperature compensate for three to five minutes prior to test.

Chapter

6

Warranty Information:

Limited Warranty:

A one year limited warranty is granted from the date of sale. This warranty includes defects in materials and workmanship only. If a problem arises from these causes please ship the unit back and we will repair or replace. If the units have been subjected to abuse or mishandling the warranty is void. If the unit has been opened without the written consent and authorization of RECLAIM Filters & Systems or an Authorized Agent the warranty is void.

There is no liability for any consequential, incidental or contingent damages whatsoever.

If the unit is repaired under warranty it is RECLAIM's responsibility to return the unit (via ground service) to the customer.

Normal shipping is FedEx Ground. Expedited shipping is available at the owner's expense.

Repairs and Warranty Claim return address:

Ozone Repair
1129 Hidden Hills Dr.
Wake Forest, NC 27587

CHAPTER

7

MSDS INFORMATION:

PRODUCT: OZONE

1. Product Identification

Synonyms: Triatomic oxygen

CAS No.: 10028-15-6

Molecular Weight: 48.0

Chemical Formula: O₃

2. Composition/Information on Ingredients

Ingredient

Ingredient	CAS No	Percent	Hazardous
Ozone gas	10028-15-6	1 - 15%	Yes

3. Hazards Identification

Emergency Overview

Highly reactive, can explode on contact with organic substances, especially strong reducing agents.

Ozone is a powerful oxidizing agent and oxidation with ozone evolves more heat and usually starts at a lower temperature than oxidation with oxygen. It reacts with non-saturated organic compounds to produce ozonides, which are unstable and may decompose with explosive violence. Ozone is an unstable gas, which, at normal temperatures, decomposes to diatomic oxygen. At elevated temperatures and in the presence of certain catalysts such as hydrogen, iron, copper and chromium, this decomposition may be explosive.

Potential Health Effects

Inhalation: Causes dryness of the mouth, coughing, and irritates the nose, throat, and chest. May cause difficulty in breathing, headache, and fatigue. The characteristic sharp, irritating odor is readily detectable at low concentrations (0.01 to 0.05 ppm).

Skin: Absorption through intact skin is not expected.

Eye Contact: Ozone is an irritant to the eyes causing pain, lacrimation, and general inflammation.

Ingestion: Not a route of exposure.

Aggravation of Pre-existing Conditions:

Ozone may increase sensitivity to bronchoconstrictors including allergens.

4. First Aid Measures

Inhalation:

Remove to fresh air; if breathing is difficult a trained person should administer oxygen. If respiration stops, give mouth-to-mouth resuscitation. Get medical attention.

Ingestion:

Not an expected route of exposure.

Skin Contact:

Wash skin thoroughly with soap and water.

Eye Contact:

Immediately flush eyes with large amounts of water for at least 15 minutes, while forcibly holding eyelids apart to ensure flushing of the entire eye surface. If irritation, pain, or other symptoms persist seek medical attention.

Acute:

May cause irritation of skin, eyes, and mucous membranes of the respiratory tract. Drowsiness, dizziness, headache, and fatigue have been associated with exposure.

Chronic:

Long term health effects are not expected from exposures to ozone. A partial tolerance appears to develop with repeated exposures.

5. Fire Fighting Measures

Flash Point:

N/D

Auto ignition Temperature:

N/D

Flammable Limits in air, % by volume - Upper: N/D **Lower:** N/D

Extinguishing Media:

Use extinguishing media suitable for surrounding fires.

Unusual Fire and Explosion Hazard: None expected. Since ozone is highly unstable and decomposes under all conditions and is not encountered except at very small levels in the immediate vicinity where formed.

6. Accidental Release Measures

Evacuate danger area. Open doors and windows to allow area to ventilate. Consult an expert.

Ozone should be contained within a chemically compatible piping system.

Ozone is a powerful oxidizing agent and oxidation with ozone evolves more heat and usually starts at a lower temperature than oxidation with oxygen. It reacts with non-saturated organic compounds to produce ozonides, which are unstable and may decompose with explosive violence. Ozone is an unstable gas which, at normal temperatures, decomposes to diatomic oxygen.

8. Exposure Controls/Personal Protection

Exposure Guidelines:

OSHA PEL: 0.10-ppm PEL/TLV

Ventilation Requirements:

General exhaust recommended. Avoid working with ozone generating equipment in enclosed spaces.

Specific Personal Protective Equipment**Respiratory:**

Respirators may be used when engineering and work practice controls are not technically feasible, when such controls are in the process of being installed, or when they fail and need to be supplemented. Respirators may also be used for operations which require entry into tanks or closed vessels, and in emergency situations.

Only appropriate respirators shall be provided and used when the use of respirators is the only means of controlling exposure for routine operations, or during an emergency. (Refer to Table 1 of ANSUI/ASTM E591-77 for appropriate respirator selection).

Positive pressure air line with mask or self-contained breathing apparatus should be available for emergency use.

Eye:

Not necessary

Gloves:

Not necessary.

Other Clothing and Equipment:

Not necessary.

9. Physical and Chemical Properties

Specific Gravity (H₂O=1):

2.144 g/L

Molecular Weight:

48.00

Boiling Point:

-111.9°C

Melting Point:

-192.7°C

Vapor Pressure:

N/A

Evaporation Rate (BuAc=1):

N/A

Vapor Density (Air=1):

1.7

Solubility in H₂O % by Weight:

0.49

Appearance and Odor:

Colorless to bluish gas with a characteristic pungent odor.

10. Stability and Reactivity

Stability:

Ozone spontaneously decomposes under all ordinary conditions, so that it is not encountered except in the immediate vicinity of where it was formed. The decomposition is speeded by solid surfaces and by many chemical substances.

Hazardous Decomposition Products:

Free radical oxygen. O[·])

Hazardous Polymerization:

Will not occur.

Incompatibilities:

Ozone is a powerful oxidizing agent and reacts with all oxidizable materials, both organic and inorganic. Some reactions are highly explosive. Alkenes, benzene and other aromatic compounds, rubber, dicyanogen, bromine diethyl ether, dinitrogen tetroxide, nitrogen trichloride, hydrogen bromide, and tetrafluorohydrazine.

11. Toxicological Information

Ozone is extremely irritating to the upper and lower respiratory tract. The characteristic odor is readily detectable at low concentrations (0.02 ppm to 0.05 ppm). Ozone produces local irritation of the eyes and mucous membranes and may cause pulmonary edema at high exposure. Systematically, ozone has been reported to mimic the effects of ionizing radiation, and may cause damage to chromosomal structures. A partial tolerance appears to develop with repeated exposures. Although most effects are acute, the possibility of chronic lung impairment should be considered, based upon animal experimentation.

12. Ecological Information

Environmental Fate:

No information found.

Environmental Toxicity:

No information found.

13. Disposal Considerations

Do not dispose of ozone off gas to atmosphere of enclosed space without properly designed off gas destruct unit. State and local disposal regulations may differ from federal disposal regulations.

14. Transport Information

Proper Shipping Name:

N/A

Hazard Class:

N/A

Identification Number:

N/A

Packing Group:

N/A

15. Regulatory Information

SARA TITLE III:

N/A

TSCA:

The ingredients of this product are on the TSCA Inventory List.

OSHA:

Nonhazardous according to definitions of health hazard and physical hazard provided in the Hazard Communication Standard (29 CFR 1910.1200)

16. Other Information

Label Hazard Warning:

HIGHLY REACTIVE. OZONE GAS AFFECTS THE RESPIRATORY SYSTEM.

Label Precautions:

Keep away from heat, sparks and flame. Avoid contact with eyes, skin and clothing. Avoid breathing. Use with adequate ventilation.

Label First Aid:

If inhaled, remove to fresh air. Get medical attention for any breathing difficulty.

Product Use:

Laboratory Reagent.

Revision Information:

Pure. New 16 section MSDS format, all sections have been revised.

Disclaimer:

RECLAIM Filters and Systems provides the information contained herein in good faith but makes no representation as to its comprehensiveness or accuracy. A properly trained person using this product intends this document only as a guide to the appropriate precautionary handling of the material. Individuals receiving the information must exercise their independent judgment in determining its appropriateness for a particular purpose. RECLAIM Filters and Systems, Inc. MAKES NO REPRESENTATIONS OR WARRANTIES, EITHER EXPRESS OR IMPLIED, INCLUDING WITHOUT LIMITATION ANY WARRANTIES OF MERCHANTABILITY, FITNESS FOR A PARTICULAR PURPOSE WITH RESPECT TO THE INFORMATION SET FORTH HEREIN OR THE PRODUCT TO WHICH THE INFORMATION REFERS. ACCORDINGLY, RECLAIM Filters and Systems, Inc. WILL NOT BE RESPONSIBLE FOR DAMAGES RESULTING FROM USE OF OR RELIANCE UPON THIS INFORMATION.