

COMPACT RECLAIM TANK

GENERAL NOTES:

1. PRECAST SPECIFICATIONS CONFORM TO LATEST ASTM C-913 SPEC FOR "REINFORCED CONCRETE WATER & WAST WATER STRUCTURES.
2. CONCRETE COMPRESSIVE STRENGTH 4000-PSI MINIMUM.
3. STEEL REINFORCING CONFORMS TO LATEST ACI-318 SPECS. FOR REINFORCED CONC.
4. PIPE CONNECTIONS TO BE SEALED WITH NON-SHRINK GROUT BY CONTRACTOR
5. SECTION JOINTS TO BE SEALED WITH NON-SHRINK GROUT BY CONTRACTOR.
6. STRUCTURE IS STEEL REINFORCED TO MEET OR EXCEED H-20 LOADING.
7. SEE PLAN VIEW FOR CORRECT ORIENTATION
8. TANK CAPACITY 4000 GALLON MIN.
9. ADJUST TANK DEPTH TO INSURE MIN GALLONAGE.
10.  BLUE DASHED ARROWS REPRESENT FLOW

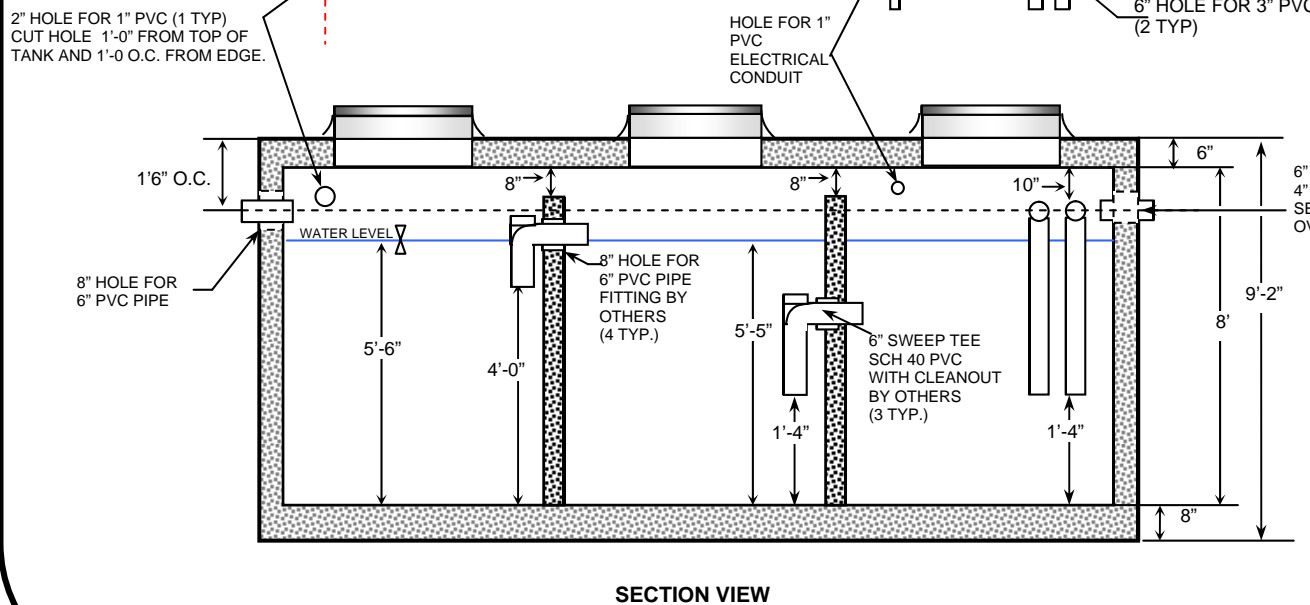
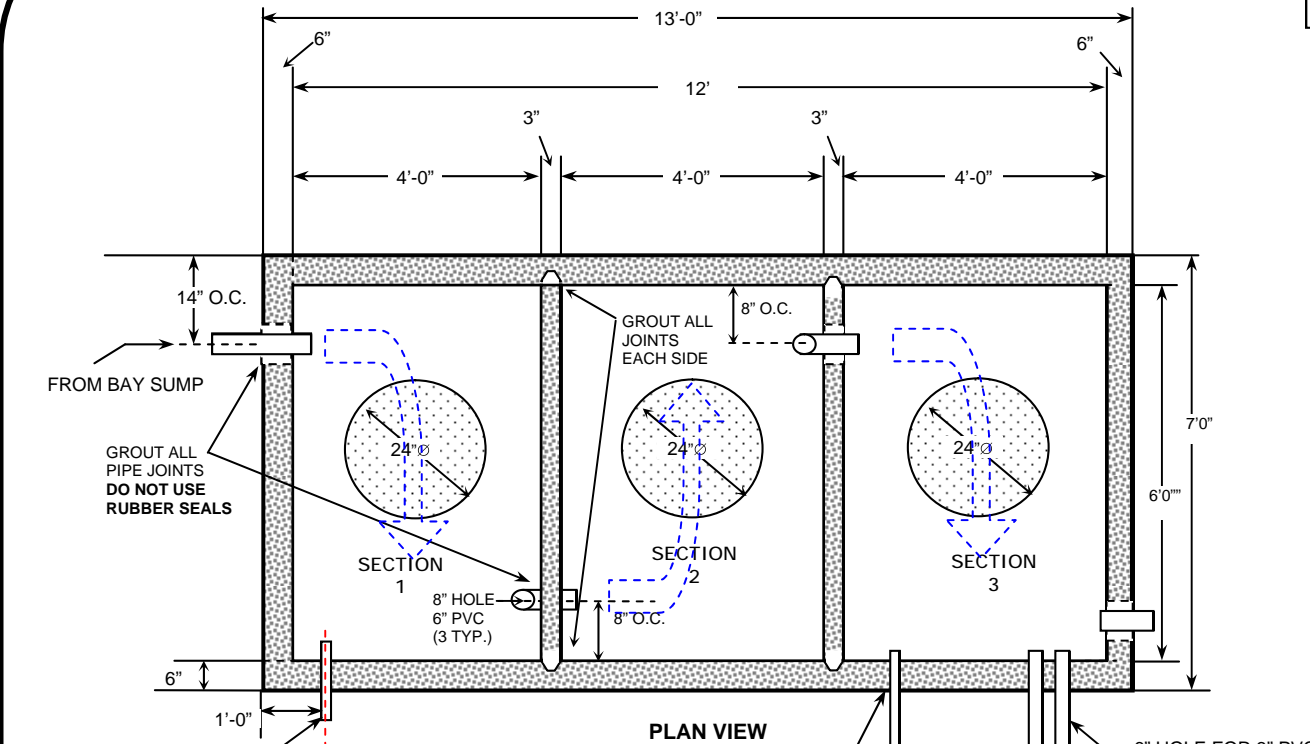

Precast Concrete In-Ground Tanking

SEE CALLOUTS ABOVE
 PLAN VIEW
4000 GALLON RECLAIM TANK
 1. REVISED 4/3/08 FOR PRECAST
 2. PLAN VIEW OF TANKING LAYOUT
 3. NOTE HOLE SIZE FOR PIPE
 4. CONTACT RECLAIM FOR FITTING DETAIL

